

Standard and Hi-Temp Cartridge Heaters



Cartridge Heaters

TUTCO Cartridge Heaters are high watt density heaters that provide excellent heat transfer efficiency and up to 100 W/in² with high operating temperatures. The Hi-Temp Cartridge is made to withstand a sheath Hi-Temperature of up to 1400 °F (760 °C), internally up to 1600 °F (871 °C). Its swagged construction allows for minimal air gaps, providing superior heat transfer and resistance to impact and vibration. Dual voltage and three phase options are available on selected diameters.

Applications

TUTCO Cartridge heaters are ideal for high heat and applications with excessive vibration characteristics. Applications like hot stamping, sealing bars, forming and heating platens may have indexing parts that are suited for TUTCO Hi-Temp Cartridge heaters rugged construction. Like Standard Cartridge heaters, many options are available to customize Hi-Temp Cartridge heaters. Select Hi-Temp Cartridge heaters for applications involving high heat and/or excessive vibration. Consult the factory for additional information and product options to meet



Standard VS. Hi-Temp

Choosing the right cartridge heater for you application.



Standard Cartridge Heaters

TUTCO Standard Cartridge Heaters are designed as an economical quality heater for lower temperature use (typically 40 watts per square inch, depending on the application). They are made to withstand internal temperatures up to 1000°F (538°C) and feature a stainless steel sheath for resistance to oxidation. High purity magnesium oxide (MgO) fills any space around resistor wire in order to optimize heat transfer and increase the life of the heater.

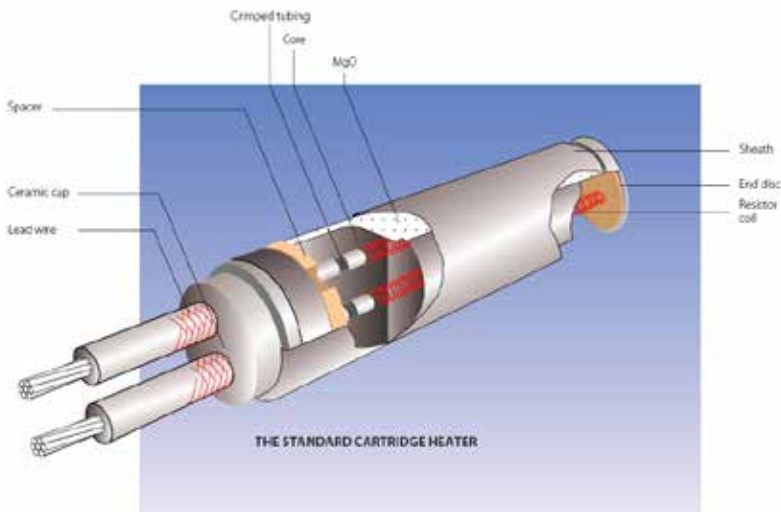

Material and Construction

- Computer-designed specification.
- 304 Stainless steel sheath for oxidation resistance
- Ceramic insulator spaces helically wound resistor inside the sheath.
- Helically wound nickel chromium resistor is of a conservative design for each application and evenly stretched through the ceramic insulators.
- Fine grain high purity magnesium oxide (MgO) fills any voids around the resistor wire to optimize heat transfer, dielectric strength and life of the heater.
- Resistor wire is joined to the leads by placing each end into nickel chromium which, upon crimping, affords positive and consistent junction.
- U.L. Approved, C.S.A. certified flexible nickel leads attached to nickel pins from within the heater 482°F (250°C), standard. Mica tape insulated 842°F (450°C), available when requested as dictated by the application.
- Disc end of heater rests on a mica insulator and is held in position when the sheath is rolled over onto it. This is the standard assembly procedure unless the application requires moisture or waterproof sealing, at which time the end cap can be sealed by brazing or welding.
- Ceramic cap standard. Cement epoxy, or RTV seal is also available.

Hi-Temp Cartridge Heaters

Our ruggedly constructed, high watt density Hi-Temp Cartridge Heaters provide excellent heat transfer efficiency, High temperature (typically 90 to 95 watts per square inch depending on the application) and long life. The Hi-Temp cartridge is made to withstand internal temperatures up to 1600°F (871°C). Its swagged construction allows for minimal air gaps, providing superior heat transfer and resistance to impact and vibration. Dual voltage and three-phase cartridges are available.



Material and Construction

- Computer-designed specification.
- High-quality resistor wire precisely wound on magnesium oxide cores.
- Resistor core assemblies accurately and consistently spaced close to the outer sheath for efficient heat transfer.
- High purity magnesium oxide (MgO) surrounds the resistor core assembly.
- Initial heater diameter is reduced thus increasing density of the assembly, resulting in a heating source which exhibits exceptional dielectric strength and heat transfer characteristics.
- End disc is always welded in place, preventing contaminants from entering the heater.
- U.L. Approved, C.S.A. certified flexible nickel leads attached to nickel pins from within the heater 482°F (250°C), standard. Mica tape insulated 842°F (450°C), available when requested as dictated by the application.
- Incoloy® 800 sheath material.
- Cement is standard. Epoxy or RTV seal is also available.
- Cold sections vary depending upon heater length and diameter.

Standard and Hi-Temp Style Comparison

	Standard	Hi-Temp
Max Watts/sq. in.	45 Watts/sq. in.	100 Watts/sq. in. Call factory for exceptions.
Max Sheath Hi-Temp	1000 °F (538 °C)	1400 °F (760 °C)
Sheath	Stainless Steel Sheath	Incoloy Sheath
Diameters	Imperial Sizes Only	Metric & Imperial Sizes Available
Cap Seal	Ceramic cap standard; cement, epoxy or RTV seal also available.	Ceramic cap standard; cement, epoxy or RTV seal also available.
Country of Manufacture	Made in USA	USA and Global Manufacture
Computer designed specifications	Yes	Yes
Fast heating coil winding design	Yes	Yes
Fine grain high purity magnesium oxide (MgO) fills	Yes	Yes

Available Configurations

TUTCO Cartridge heaters can be ordered in a variety of configurations to meet your specific application.

Lead Options



Flexible Leads

Internally connected leads. For applications requiring maximum flexibility at lead exit. 10" (25.4 cm) leads standard, other lengths are available.



Externally Connected Leads

Hi-Temp Cartridges are provided with approx. 1" (25.4 mm) sleeving over lead junction as standard. 10" (25.4 cm) leads standard, other lengths are available.



Straight Leads with Clip Support

Clip support helps to minimize lead breakage where leads exit heater. 10" (25.4 cm) leads standard, other lengths are available.



90° Leads

Leads exit at 90° angle for applications requiring small radius bends, lead wire protection and where space is limited. 10" (25.4 cm) braid standard, other lengths are available. Order by overall length.



90° Leads with Clip

Clip support helps to minimize lead breakage where leads exit heater. 10" (25.4 cm) leads standard, other lengths are available.

Lead Protection



Straight Strain Relief Spring

Straight strain relief spring minimizes bending strain on lead wires. Spring extends approximately 3" (76.2 mm) beyond end of sheath.



Stainless Steel Braid

Stainless steel braid over lead wires. For applications requiring small radius bending and lead wire abrasion protection. 10" (25.4 cm) braid standard, other lengths are available.



Stainless Steel Armor

Straight stainless steel armor cable protects leads from abrasion. Sizes include: 1/4", 5/16", 1/2", and 5/8". 10" (25.4 cm) standard, other lengths are available.



Convoluted Armor

Used in situations that require moisture resistant armor. Available in most instances in which armor is utilized. Sizes: 3/8", and 5/8" only. 10" (25.4 cm) standard, other lengths are available.



Right Angle Elbow

Right angle copper elbow for applications requiring right angle lead exit. Moisture-resistant seal is optional. 10" (25.4 cm) leads standard, other lengths are available.

Fittings



NPT Bushing

Hex head N.P.T. bushing attached. Must specify insert length and bushing material. Sheath material types: stainless steel, cold rolled or galvanized. Bushing material types: brass, stainless steel or steel. 10" (25.4 cm) leads standard, other lengths are available. Octagonal box available.



Hex Center Bushing

Hex head N.P.T. bushing attached. Must specify insert length and bushing material. Sheath material types: stainless steel or brass. Bushing material types: brass, stainless steel or steel. 10" (25.4 cm) leads standard, other lengths are available. Octagonal or explosion-proof boxes can be adapted to both Standard and Hi-Temp Cartridge heaters.



Adapter

Must specify insert length and bushing material. Sheath material types: stainless steel, cold rolled or galvanized. Bushing material types: brass, stainless steel or steel. 10" (25.4 cm) leads standard, other lengths are available.



Adapter with Hex Head

Must specify insert length. Bushing material is copper. 10" (25.4 cm) leads standard, other lengths are available.

Screw Terminals



External Pins

For applications with high amps requiring universal connection capability. Screw terminals are attached to external pins.



Flush with Cap

Hi-Temp Cartridges are provided with approx. 1" (25.4 mm) sleeving over lead junction as standard. 10" (25.4 cm) leads standard, other lengths are available.



Either End

Other Options



Armor with Plug

Armor cable with power plug attached. Must specify armor length and Hubbell® power plug number. Moisture-resistant armor available. Other Plugs are available. Also available with Hex Head NPT bushing and armor.

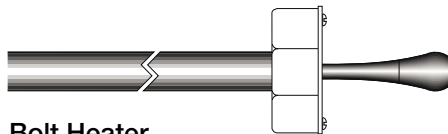

Bolt Heater

Bolt heaters are designed to heat drilled metal surfaces quickly while minimizing heat loss to surrounding areas. Each is designed to expand drilled bolts or studs while maintaining a uniform heat throughout its heated length are available.

Hi-Temp Cartridge Heater Control

TUTCO Cartridge heaters can be ordered in a variety of configurations to meet your specific application.

Thermocouple Options



Bottom Grounded

For fast response, heater is positioned in a blind hole or where material flows past or encompasses the heater. The end disk is always welded in place. Machined flat up to 1/2" (12.7 mm) dia.



Bottom Ungrounded

Where circumstances are such that an ungrounded thermocouple is required.



Center Grounded

Selected when a fast response is required. The thermocouple can be located in any position along the length of the heater. Standard location is midway along the length with approximately 1/4" (6.4 mm) cold section on either side of the junction. Not available on 1/4" diameter heaters.



Center Ungrounded

The thermocouple is positioned internally and ungrounded to monitor the heater temperature. Generally used in research and development applications.



Removable Thermocouple

The thermocouple is inserted down a hypotube for easy removal.

Avoiding Common Heater Failure Modes

Use recommended maximum watt density range to avoid excessive watt densities which result in the internal overheating of the heater.

A clean and properly bored hole in relation to heater diameter is required for quality heat transfer.

Be aware that moisture/contamination will reduce the life expectancy of a heater. Consider specifying that either the disc or lead end or both be sealed depending upon the specific conditions to which the heater is being subjected.

Review lead exit variations and select the style that best suits your particular application. Consider such conditions as contamination, abrasion, flexing and sharp bending of the leads as they exit the heater.

It is recommended that watt density be reduced by 20% for those heaters subjected to frequent cycling.

To avoid burn-out by operating in open air, heated length must be fully inserted. In addition, an exposed heated section of the heater may cause a hazardous condition.



Diameter Sizes

	Standard	Hi-Temp
Imperial Sizes	Actual Diameter	Actual Diameter
3/16"	0.183" ± 0.001"	N/A
1/4"	0.245" ± 0.002"	0.247" ± 0.002"
5/16"	0.308" ± 0.002"	0.310" ± 0.002"
3/8"	0.370" ± 0.002"	0.370" ± 0.002"
7/16"	0.432" ± 0.002"	0.432" ± 0.002"
1/2"	0.494" ± 0.003"	0.495" ± 0.002"
9/16"	0.562" ± 0.003"	0.560" ± 0.002"
5/8"	0.620" ± 0.003"	0.620" ± 0.002"
11/16"	0.681" ± 0.003"	0.681" ± 0.002"
3/4"	0.744" ± 0.003"	0.744" ± 0.002"
13/16"	0.812" ± 0.003"	0.812" ± 0.003"
7/8"	0.869" ± 0.003"	0.869" ± 0.002"
15/16"	0.932" ± 0.003"	0.932" ± 0.002"
1"	0.992" ± 0.003"	0.995" ± 0.003"
1-1/4"	1.244" ± 0.003"	N/A

	Standard	H-Temp
Metric Sizes	Actual Diameter	Actual Diameter
6.5 mm	N/A	6.43 mm ±0.05 (0.253" ±0.002)
8.0 mm	N/A	7.92 mm ±0.05 (0.312" ±0.002)
10 mm	N/A	9.93 mm ±0.05 (0.391" ±0.002)
11.9 mm	N/A	11.81 mm ±0.05 (0.465" ±0.002)
12 mm	N/A	11.91 mm ±0.05 (0.469" ±0.002)
12.5 mm	N/A	12.42 mm ±0.05 (0.489" ±0.002)
12.7 mm	N/A	12.62 mm ±0.05 (0.497" ±0.002)
14 mm	N/A	13.87 mm ±0.05 (0.546" ±0.002)
15 mm (Sleeved)	N/A	14.91 mm ±0.05 (0.587" ±0.002)
16 mm	N/A	15.93 mm ±0.05 (0.627" ±0.002)
17.5 mm	N/A	17.32 mm ±0.05 (0.682" ±0.002)
19.5 mm	N/A	19.51 mm ±0.05 (0.768" ±0.002)



931.432.4141
500 Gould Drive, Cookeville, TN 38506
customerservice@tutco.com
www.tutco.com